

155° hinge

Web code  
DQDHEM

Planning

Hinge dimensions and gap calculation based on factory setting (mounting plate spacing = 0 or 9 mm)

Hinge and front protrusion at 90° opening angle

Overlay application  
0-protrusion

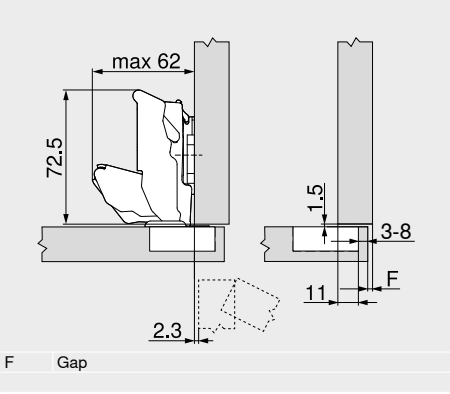
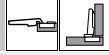

Dual application

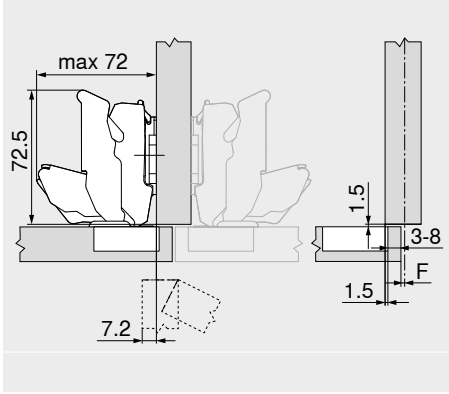
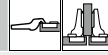

Inset application

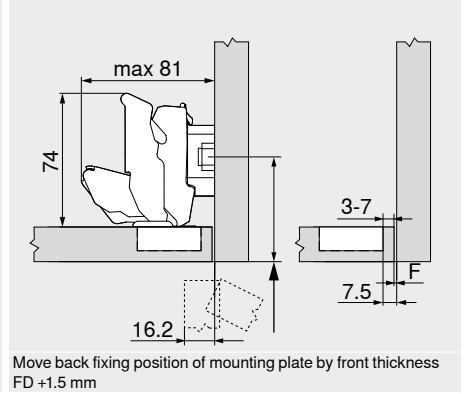
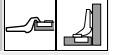

Drilling distance TB

MD	Front overlay FA (mm)																		
	5	6	7	8	9	10	11	12	13	14	15	16	17	18	19				
0													3	4	5	6	7	8	
3							3	4	5	6	7	8							
6				3	4	5	6	7	8										
9	3	4	5	6	7	8													
MD	Mounting plate spacing (mm)																		

MD	Front overlay FA (mm)																						
	-4.5	-3.5	-2.5	-1.5	-0.5	0.5	1.5	2.5	3.5	4.5	5.5	6.5	7.5	8.5	9.5								
0																	3	4	5	6	7	8	
3																		3	4	5	6	7	8
6																							
9																							
MD	Mounting plate spacing (mm)																						

MD	Front overlay FA (mm)				
	-4.5	-3.5	-2.5	-1.5	-0.5
0					
3					
6					
9					
MD	Mounting plate spacing (mm)				

Minimum gap F for fronts with a front radius (R = 1 mm) based on the factory setting

Drilling distance TB (mm)	Front thickness FD (mm)												
	20	21	22	23	24	25	26	27	28	29	30	31	
3	0	0	0	0	0	0	0.5	0.5	1.0	2.0	2.0	3.0	4.5
4	0	0	0	0	0	0	0.5	1.0	2.0	2.0	2.5	4.0	
5	0	0	0	0	0	0	0.5	1.0	2.0	2.0	3.5		
6	0	0	0	0	0	0	1.0	1.5	2.0	3.0			
7	0	0	0	0	0	0	1.0	1.5	2.5				
8	0	0	0	0	0	0	1.0	1.5					

We recommend a trial application for an overlay application against a wall

110° Opening angle stop  
92° Opening angle stop

Adjustment

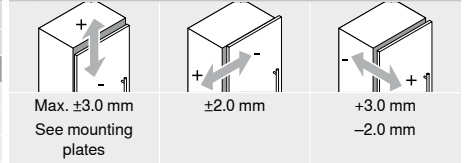

Screw-on

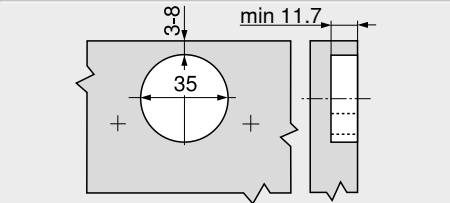

INSERTA | knock-in

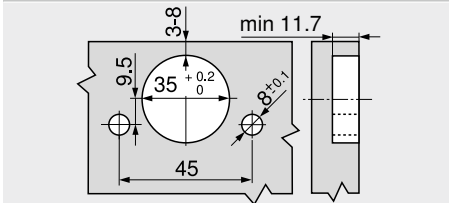

Hinge boss dimensions

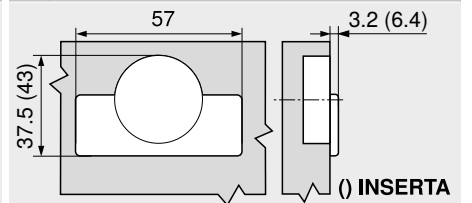

Reference pages

Overview – CLIP top BLUMOTION   CLIP top – hinges	71
Mounting plates	144
Accessories – hinge arm cover cap	151
Accessories – general	153
Overview – TIP-ON for doors	171
Overview – assembly devices	591
More technical details	698

Assembly, removal and adjustment

Short URL  
[www.blum.com/a210](http://www.blum.com/a210)

