

**Blind corner hinge overlay application**



Web code – click on the code or enter it in the Product Configurator

DQDKXA

**Planning**

Hinge dimensions and gap calculation based on factory setting (mounting plate spacing = 3 mm)

Hinge and front protrusion at full opening angle

**Overlay application**

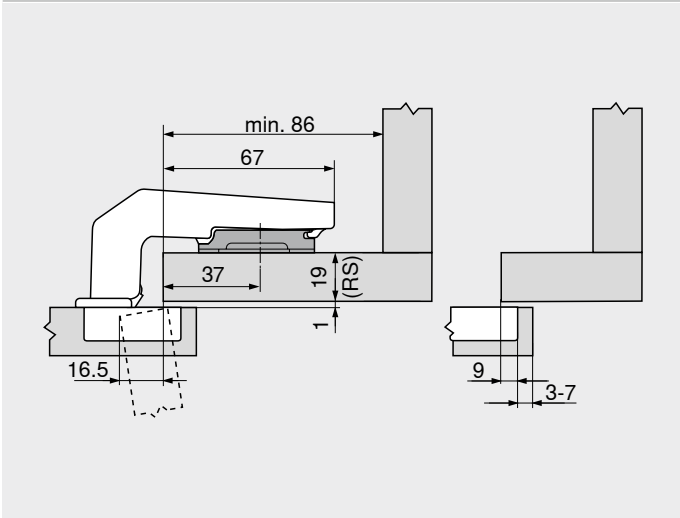

Frame thickness RS (mm)	Mounting plate spacing (mm)
16	6
19	3
22	0

**Minimum gap F for fronts with a front radius (R = 1 mm) based on the factory setting**

Drilling distance TB (mm)	Front thickness FD (mm)											
	16	18	19	20	22	24	26	28	29	30	31	32
3	0.2	0.3	0.4	0.5	0.8	1.0	1.5	1.9	Δ	Δ	Δ	Δ
4	0.2	0.3	0.4	0.5	0.7	1.0	1.4	1.8	Δ	Δ	Δ	Δ
5	0.2	0.3	0.4	0.5	0.7	1.0	1.4	1.8	Δ	Δ	Δ	Δ
6	0.2	0.3	0.4	0.5	0.7	1.0	1.4	1.8	Δ	Δ	Δ	Δ
7	0.2	0.3	0.4	0.5	0.7	0.9	1.4	1.7	Δ	Δ	Δ	Δ

Δ In these cases a trial is recommended

**Adjustment**

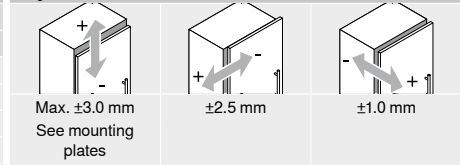

**Screw-on**

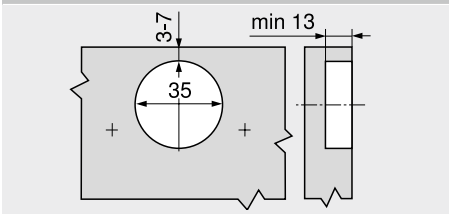

**INSERTA | knock-in**

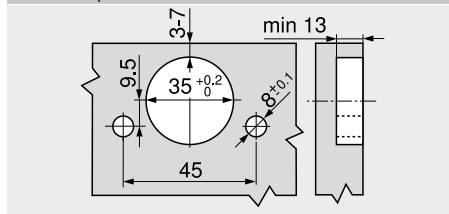

**Hinge boss dimensions**

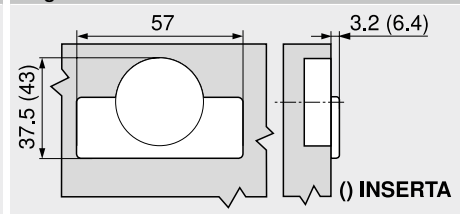

**Reference pages**

Overview	73
Mounting plates	150
Accessories – hinge arm cover cap	157
Accessories	159
TIP-ON for doors	190
Blum services	602
More technical details	708

**Assembly, removal and adjustment**

Short URL  
[www.blum.com/a210](http://www.blum.com/a210)

