

Blind corner hinge inset application



Web code – click on the code or enter it in the Product Configurator

DQE4MM

Planning

Hinge dimensions and gap calculation based on factory setting (mounting plate spacing = 3 mm)

Hinge and front protrusion at full opening angle

Inset application



Fixing position from inside edge of muntin: 14 mm
 Cruciform mounting plate – blind corner hinge inset application – 14/32
 F Gap

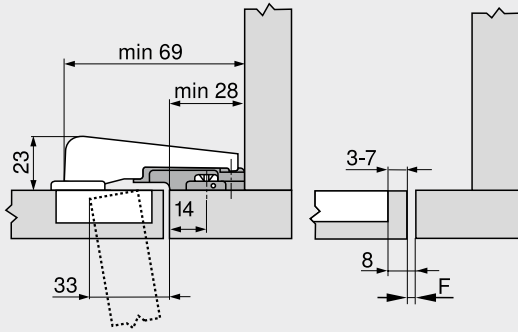

Minimum gap F for fronts with a front radius (R = 1 mm) based on the factory setting

Drilling distance TB (mm)	Front thickness FD (mm)											
	16	18	19	20	22	24	26	28	29	30	31	32
3	0.2	0.3	0.4	0.5	0.8	1.0	1.5	1.9	Δ	Δ	Δ	Δ
4	0.2	0.3	0.4	0.5	0.7	1.0	1.4	1.8	Δ	Δ	Δ	Δ
5	0.2	0.3	0.4	0.5	0.7	1.0	1.4	1.8	Δ	Δ	Δ	Δ
6	0.2	0.3	0.4	0.5	0.7	1.0	1.4	1.8	Δ	Δ	Δ	Δ
7	0.2	0.3	0.4	0.5	0.7	0.9	1.4	1.7	Δ	Δ	Δ	Δ

Δ In these cases a trial is recommended

Adjustment

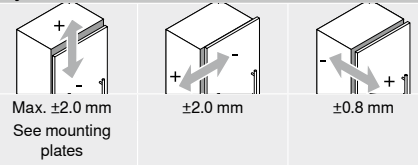

Screw-on

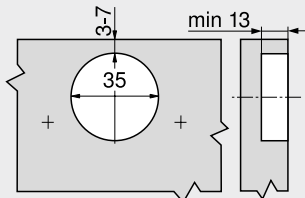

Hinge boss dimensions

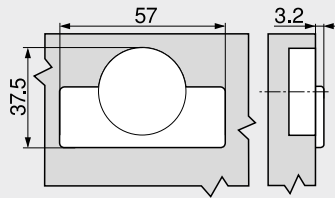

Reference pages

Overview	163
Mounting plates	170
Accessories – hinge arm cover cap	173
Accessories	174
TIP-ON for doors	190
Blum services	602
More technical details	708

Assembly, removal and adjustment

Short URL
www.blum.com/a240

